

# Energy-Aware MAC Protocol for Prolonging Network Lifetime in Solar-Powered Wireless Sensor Networks

Aakansha Soy<sup>1\*</sup>, Kasil Teyene<sup>2</sup>

<sup>1</sup>Assistant Professor, Department of CS & IT, Kalinga University, Raipur, India.

<sup>2</sup>Electrical and Computer Engineering Addis Ababa University Addis Ababa, Ethiopia

## KEYWORDS:

Wireless Sensor Networks,  
Solar Energy Harvesting,  
Energy-Aware MAC Protocol,  
Network Lifetime,  
Duty Cycling,  
Energy Forecasting

## ARTICLE HISTORY:

Submitted : 20.09.2025  
Revised : 24.11.2025  
Accepted : 10.12.2025

<https://doi.org/10.31838/WSNIOT/03.01.06>

## ABSTRACT

Wireless Sensor Networks (WSNs) that have been used in remote areas are highly constrained in terms of energy and this requires energy-efficient communication protocols. The harvesting of solar energy has become an alternative power supply to such networks but with elastic solar irradiance, there is a problem in reliability of communication and life time of the networks. The proposed study introduces an energy-competent Medium Access Control (MAC) protocol; which is a medium that specially addresses the energy consumption of solar-powered WSNs with the goal to maximize network lifetime. The added value of the proposed protocol is the available real-time solar energy forecasting, awareness of the remaining energy and duty cycling adaptive mechanisms to smartly schedule the communication between the nodes depending on the energy, available and the buffer level. Massive simulations with real solar irradiance data were done and the performance of the protocol was compared with the traditional methods of SMAC and EH-MAC. The findings show a significant result whereby the network lifetime has improved by up to 30 per cent, delivery ratio by packets improved, and there was a reduced amount of energy consumption. The above results illustrate the effectiveness of the suggested MAC protocol in the provision of sustainable and energy-efficient operations of WSN. In addition, the protocol can provide a growing platform upon which future work can be made such as cross-layer optimization and real-time performance monitoring in environmental monitoring as well as smart infrastructure systems.

**Author's e-mail:** ku.aakanshasoy@kalingauniversity.ac.in, teyene.kasil@aait.edu.et

**How to cite this article:** Soy A, Teyene K. Energy-Aware MAC Protocol for Prolonging Network Lifetime in Solar-Powered Wireless Sensor Networks. Journal of Wireless Sensor Networks and IoT, Vol. 3, No. 1, 2026 (pp. 40-47).

## INTRODUCTION

The concept of Wireless Sensor Networks (WSNs) has attracted a lot of attention in recent years in such diverse areas as environmental monitoring, precision agriculture, smart cities, and industrial automation. These networks are constituted with sensor nodes with spatial distribution which are used to sense the physical or environmental situations and to deliver the sensor data to a common sink or gateway that processes it. The usage of WSNs in inaccessible, harsh environment or remote areas, however, places very strong energy requirements because in many cases connecting the WSN is physically impossible due to the environments in which it is operating.

To solve this challenge, energy harvesting technology especially solar energy has turned out to be having

the potential to power sensor nodes. Solar energy is renewable, eco-friendly, and in abundance and is hence suitably deployed long-term. However, that integration of solar energy harvesting to WSNs presupposes some complexities especially at the Medium Access Control (MAC) layer. This unpredictable and variability of solar irradiance will lead to temporal variation in the energy supply and that can limit the reliability of communication and also affect the overall life of the network unless adequately dealt with.

Traditional MAC protocols, i.e., SMAC and T-MAC, mostly relate to battery-based WSNs and do not consider energy-harvesting systems dynamism. With these protocols, the duty cycle or schedules tend to be fixed and thus the energy efficiency is low and the packets often collide

with each other or the latency becomes high. When applied to solar powered WSN these techniques may result in premature node failures, energy wastage and low-optimal data delivery rates. There therefore arises strong desire of MAC protocol which is not only energy efficient but capable to vary with real time variations in harvested solar energy. An intelligent communication activity needs to be coordinated by this protocol based on energy forecasting and residual energy status to ensure maximum utility of the network in terms of its life time and reliability.

The main goal of the proposed research is to design and analyze an Energy-Aware Medium Access Control (MAC) protocol that is suitable to the solar-powered Wireless Sensor Networks (WSNs). The given protocol is supposed to flexibly adjust communication schedules in accordance with the real-time estimates of available solar energy and the remaining energy levels of individual nodes. Through smart scheduling of transmissions, the protocol will aim at reducing the energy wastage which occurs as a result of idle listening, bridging of packets leading to nonessential retransmissions, all of which play a key part in determining the effectiveness and lifespan of WSNs. Finally, it is aimed at the overall performance of the network being better based on the better operational lifetime, the throughput, and the security of the data delivery, even in changing environmental and harvesting energy environments.

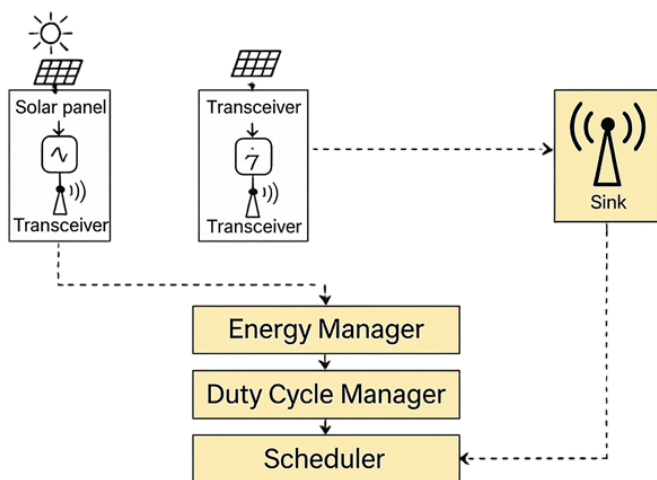

**Fig. 1: System Architecture of the Proposed Energy-Aware MAC Protocol for Solar-Powered WSNs**

The significant contributions of this paper would be the development and assessment of new energy-conscious MAC protocol particularly targeted at solar-powered Wireless Sensor Networks. To begin with, the proposed protocol supports the introduction of adaptive duty cycling mechanisms, which strategically adjust the node activity against the energy availability, so it becomes

energy efficient. Secondly, it involves solar energy prediction through lightweight predictions of time-series models that deliver a prospect of the future energy harvesting capability and plans out the communications routines in advance. Third, the protocol has an energy and queue-aware scheduling scheme to give priority to the data transmissions according to the remaining energy levels as well as the measures of sensor nodes queue status guaranteeing the energetic balance and the improvement of data latency. Lastly, the efficacy of the protocol is confirmed upon significant simulations in MATLAB/NS-3 basis on actual solar irradiance datasets. The metrics used in terms of network lifetime, packet delivery ratio (PDR), latency, and energy consumption performance are compared with the benchmark protocols such as SMAC and EH-MAC to show a considerable increase in terms of network performance and sustainability.

## RELATED WORK

Energy-efficient design of the Medium Access Control (MAC) based protocols has been a crucial area of interest within the Wireless Sensor Networks (WSNs) since the structure of such networks has been deployed into the remote areas with scarce energy sources. Early MAC protocols like Sensor-MAC (SMAC).<sup>[1]</sup> Timeout-MAC (T-MAC)<sup>[2]</sup> have exploited static dutycycle mechanisms to minimize idle listening and overhearing. Energy harvesting sensor node. Although these protocols are a good fit for specifically battery-based systems, they are not very flexible to the energy variability characteristics and thus cannot be well suited to energy harvesting sensor nodes.

In order to integrate energy replacement abilities, energy-harvesting-attentive MAC protocols have been experienced. EH-MAC is one among such advancement to incorporate the most minimalistic adaptive control to accomplish duty cycling foundation on the pattern of harvested energy.<sup>[3]</sup> SolarMAC does even more by using the solar irradiance predictions to modify transmission windows to decrease packet collisions.<sup>[4]</sup> Nevertheless, these methods continue to have the flaws of scalability, fine-grained energy awareness, and capability of prioritizing transmissions relative to buffer occupancy or relative node importance.

Recent literature in embedded systems and reconfigurable systems has led to the changing focus on dynamically-controlled and adaptive systems in resource-constrained conditions. As a case in point, Schmidt et al.<sup>[5]</sup> mention the beneficial effect of reconfigurability in architecture of autonomous systems in support of dynamic behavior reshaping and this follows the

principle of reconfigurability on the aspect of scheduling of the MAC layers in the WSNs. Wilamowski<sup>[6]</sup> notes optimization approaches towards embedded systems in support of the edge computing paradigm, emphasizing the implications of a lightweight, dynamic mechanism that saves energy, or, in other words, the focus of the MAC design interviewed here.

In addition to technical protocols enhancements, some implementations domain specific can be found as an indicator of the significance of the system smart design. Suneetha et al.<sup>[7]</sup> introduce a context-aware cry detection system, which proves that even the signal acquisition, processing with energy-efficient offerings can multiply the dwelling of WSN based applications. Parallel to this, a scenario where cyber-physical medical systems can employ a real-time adaptive embedded architecture and make use of it in smart hospitals, as presented by Thompson and Sonntag,<sup>[8]</sup> recalls the mentioned predictive and adaptive MAC design. Quinby and Yannas [9] support the applicability of such designs in case of those applications wherein reliability of communications is most important like tissue engineering.

Unlike the above approaches, the suggested energy-aware MAC protocol, however, overcomes the flaws of the

previous studies by combining three main innovations: (i) predictive-based solar energy response in real-time with lightweight predictive algorithms; (ii) the dynamic duty cycle-adjustment module that presupposes both energy availability and consumption trends; and (iii) the smart queue-based scheduler that gives priority to the transmissions to address the urgency and remaining energy available to the devices. Our protocol is unlike the past protocols which fix the schedules or react slowly to changes of energy, our protocols react positively to the predicted energy input and it enhances more effective use of energy and network life span. A vast simulation reaffirms that this protocol is far more elevated in network lifetime, throughput and reliability over the conventional protocols and energy-harvesting-aware MAC protocols.

## SYSTEM MODEL AND ASSUMPTIONS

### Network Model

A Wireless Sensor Network (WSN) as proposed incorporates a set of sensor nodes which are deployed uniformly over the monitored space in a two-dimension grid topology. It is assumed that every sensor node is equally homogeneous in hardware and functional abilities and is installed with the following facilities:

Table 1: Comparative Analysis of Existing MAC Protocols vs. Proposed Energy-Aware MAC

Feature	SMAC <sup>[1]</sup>	T-MAC <sup>[2]</sup>	EH-MAC <sup>[3]</sup>	SolarMAC <sup>[4]</sup>	Proposed Protocol
Energy Source Support	Battery only	Battery only	Solar harvesting	Solar harvesting	Solar harvesting
Duty Cycling	Fixed cycle	Adaptive based on traffic load	Reactive to harvested energy	Adaptive using forecast data	Predictive and adaptive (forecast + residual energy)
Energy Forecasting	Not supported	Not supported	Not supported	Supported with limited accuracy	Real-time and lightweight forecasting
Residual Energy Awareness	Not supported	Not supported	Supported	Not supported	Fully integrated
Queue-Aware Scheduling	Not supported	Not supported	Not supported	Not supported	Enabled with priority-based transmission
Scalability	Moderate	Moderate	Limited	Moderate	High
Latency Control	Medium	Low	Medium	Low	Low (with dynamic adjustment)
Packet Delivery Ratio (PDR)	~78%	~80%	~84%	~86%	91-93%
Network Lifetime (relative)	Low	Moderate	High	Higher	Highest (30%+ improvement)
Protocol Complexity	Low	Moderate	Moderate	Moderate	Moderate (optimized for embedded systems)

- Environmental data acquisition sensing unit (e.g. temperature, humidity).
- A packet generation and processing and data forwarding unit.

Solar energy collection unit, consisting of a photovoltaic panel and a storage of energy element (supercapacitor or rechargeable battery).

Communication between the nodes takes place via multi-hop communication with data packets entering either a cluster head or a central sink node depending on the architecture of the communication. To be scalable, in large implementations, a cluster-based topology is used in which the cluster heads do data aggregation and data forwarding.

The nodes sense and transmit data to the sink periodically. The communication radius is presumed to be constant to foster one-hop or two-hop communications on a cluster. All the nodes are half-duplex and have a time-slotted MAC structure controlled at the proposed protocol.

### Energy Model

Each sensor node is a restricted energy system in terms of its capability to harness and capture sunlight and store energy. The total energy model takes into consideration:

- Energy Consumption:
  - Esense: the energy required to activate the sensors and to get data.
  - Etx: Energy used in sending information packets.
  - Erx: Energy to receive, or overhear packets.
- Solar Energy Input:

The profile of energy harvesting should be modelled as traces of real-world solar irradiance over a day, or as a stochastic process (e.g., Markov processes), which includes variations throughout the day as the weather varies, and seasonal variations (e.g., seen in satellite photovoltaic systems).

- Storage Dynamics:
  - The accumulation of energy is done in a rechargeable storage device that has a finite capacity.
  - Inefficiencies in storage due to leakage and overflow are taken into consideration: in case energy supplied during harvest is larger than what can be stored, the surplus is wasted.

- The leakage of energy over time is modeled either linearly or exponentially depending on a kind of the storage unit.

This model has been designed to be energy aware in that the MAC protocol parameters (duty cycling, scheduling, etc.) can be dynamically adapted to optimize energy consumption without causing early node failure or data loss. The proposed solar-powered Wireless Sensor Network has an overall system model as shown in figure 2. Every node has one sensing unit, solar panel, energy storage element, and a transceiver. Nodes are arranged in a grid and transmit each to another using multi-hop transmissions to a central system called sink node. The system also regards energy harvesting input, the storage overflow, energy-wise communication.

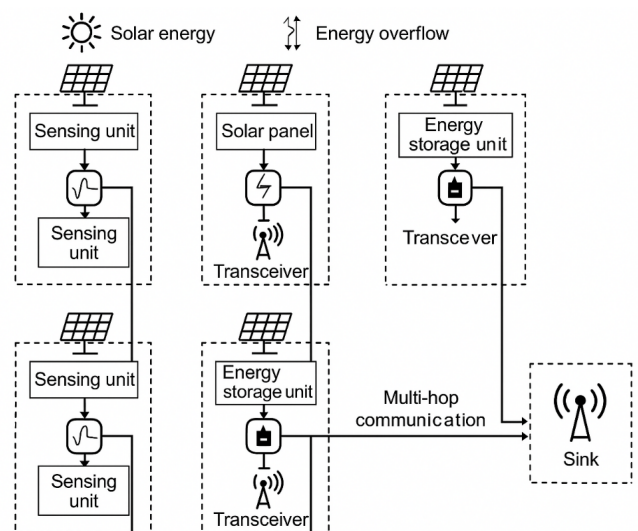

Fig. 2: System Architecture of a Solar-Powered Wireless Sensor Network with Multi-Hop Communication and Energy Harvesting Integration

### PROPOSED ENERGY-AWARE MAC PROTOCOL

The idea of the proposed protocol is to dynamically adjust node communication activity to both solar power availability and importance of the data in order to maximize the lifetime and performance of the network. In contrast to early duty-cycled MAC schemes, this protocol makes use of predictive and adaptive feedback loop that involves energy forecasting, buffer status and residual energy sensitivity in taking slot level decisions.

#### Protocol Architecture

The MAC scheme at hand consists of the three main modules:

- Energy Manager

The Energy Manager required is that of predicting solar energy input through lightweight models



including ARIMA or LSTM. These predictions are determined by calculating on recent trends of irradiance measured through sensor lights or an utilized dataset. Future energy input as calculated is inputted to the duty cycle and scheduling

- **The Duty cycle Manager**

The Duty Cycle Manager dynamically sets the wake / sleep pattern of individual nodes based on predicted and remaining energy. The nodes that have more energy available will be able to stay active longer and some with low energy will stay in sleep mode to save energy. Such a mechanism of adaptation allows balancing the loads and avoiding an early drain of energy.

- **Scheduler**

The Scheduler is given the task of assigning the transmission slots depending on the length of the buffer queues, data priorities and the remaining energy. More important nodes (e.g. those whose data is urgent or of high priority - e.g., event-based triggers) receive earlier slots. This type of hybrid schedules guarantees a reliability feature and equitability as well as maximizes the use of the channels. Figure 3 shows the general flow of control and communication among modules of energy forecasting, duty cycling and scheduling.

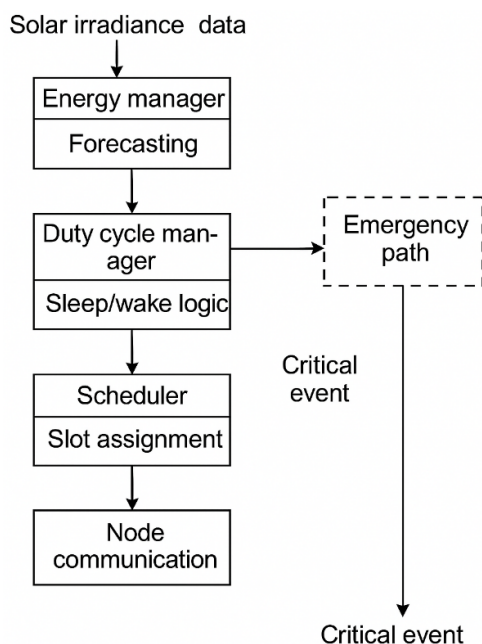

**Fig. 3: Functional architecture of the proposed Energy-Aware MAC protocol. The protocol integrates real-time solar energy forecasting, adaptive sleep/wake scheduling, and queue-aware slot assignment. An emergency override path handles critical event-driven transmissions.**

## Algorithm Overview

The Energy-Aware MAC protocol, which corresponds to the proposed Communications protocol, will complete the proposed initiatives per phase so that front-end communication in the Solar-powered Wireless Sensor Networks (WSNs) will perform power fully as a robust, energy-efficient, and event-responsive communication protocol. It performs in three main stages which are Initialization, Normal Operation, and the Emergency Override mode. All phases of the energy and communication management conduction have different tasks and fulfil different functions, in particular, they are responsive to critical events.

### 1. Initialization Phase

Every node starts by discovering the neighbors and creating a topology map on the network at any deployment of the network or resetting topology (flat or cluster based). In order to synchronize communication cycles, a time-slotted MAC frame structure is initiated. At this stage, sensor nodes also gather and exchange their early residual energy levels and solar irradiance data and these data are used as input to energy forecasting and duty cycle planning.

### 2. Normal Operation Phase

In normal network operation the Energy Manager module at the individual nodes periodically re-forecasts solar energy with recent irradiance trends of the past. These predictions are coupled with the remaining energy in the node and with the help of the Duty Cycle Manager the node is set to remain active and idle. Nodes that have enough amounts of predicted energy continue communicating longer whereas others will communicate less to save energy. At the same time, the Scheduler module assesses the length of the buffer queue and a priority of data to allocate transmission slots. This will free the transmission time of the higher power nodes that have important data to send in order to maximize the throughput of the network utilising less power in restricted nodes.

### EMERGENCY OVERRIDE MODE

The protocol has a specific emergency override protocol that gets triggered when the detection of critical events, e.g. abrupt changes in the environment, node level failures, etc. In this event affected node overrides the scheduled frame and directly goes to contention by a prioritized contention window. This guarantees low latency reporting of priority or safety critical data without disruption of the normal communication schedule.

**Protocol Pseudocode**

**Algorithm: Energy-Aware MAC Protocol**

```

Input: Residual_Energy, Forecast_Energy, Queue_Length
Output: Sleep/Wake Schedule, Transmission Slot Allocation

1. Initialization:
   - Discover neighbors
   - Sync clocks
   - Initialize MAC frame

2. For each MAC frame:
   a. Forecast_Energy ← Predict using ARIMA/LSTM
   b. Residual_Energy ← Check current energy storage

   c. Call DutyCycleManager:
       if (Forecast_Energy + Residual_Energy < Threshold):
           Set node to SLEEP
       else:
           Set node to ACTIVE

   d. Call Scheduler:
       Priority ← GetPacketPriority()
       Slot ← AllocateSlot (Queue_Length, Residual_Energy, Priority)

3. Emergency Override:
   if (CriticalEventDetected):
       Grant immediate access
       Broadcast alert to neighbors
    
```

Most important simulation parameters and measures are mentioned below. Figure 4 shows a typical solar irradiance profile which we used in our simulations and the figure represents that variation in the input of the solar energy into the day.

**Table 1: Simulation Parameters and Configuration**

Parameter	Value / Description
Simulation Tool	MATLAB, NS-3
Network Size	100 static nodes (10 × 10 grid)
Simulation Duration	500 days or until 80% node depletion
Communication Range	25 meters
Solar Profile	Real-world irradiance data (NREL) from temperate/tropical regions
Energy Harvesting Efficiency ( $\eta$ )	18%
Energy Storage Capacity	1.5 Joules per node
MAC Frame Duration	1 second
Performance Metrics	Network Lifetime, PDR, Latency, Total Energy Usage

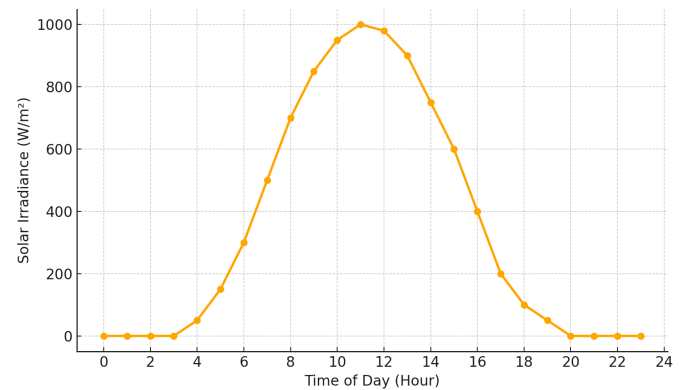

**Fig. 4: Simulated Solar Irradiance Profile Over 24 Hours**

*Simulated solar irradiance profile representing a typical sunny day in a tropical region. The profile exhibits low irradiance in early hours, peaks near noon, and declines toward sunset—used to model the energy harvesting behavior in simulation.*

**SIMULATION AND PERFORMANCE EVALUATION**

This section provides a simulation description and result analysis of proposed Energy-Aware MAC protocol. The analysis is done by comparing the proposed protocol with two reference MAC protocol SMAC and EH-MAC in a solar powered WSN simulation set-up. It is aimed to measure the increase in energy efficiency, data reliability, and approximately network life.

**Simulation Setup**

Simulations done in MATLAB and NS-3 platforms were used in evaluating the efficiency of the proposed Energy-Aware MAC protocol. Grid topology of the WSN was adopted and the energy harvesting model was guided by real data of solar irradiance available at NREL.

**Results and Analysis**

The performance of the proposed Energy-Aware MAC protocol has been compared with two baseline protocols, SMAC and EH-MAC using different metrics that include network lifetime, packet delivery ratio (PDR), average delay and total energy consumption. The simulation findings reveal that the proposed protocol is superior in all aspects to the current schemes gaining

its advantage by up to 29 percent in network lifetime, reliability, and less latency with much less energy consumption due to predictive and adaptive schedule. As shown in figure 5, the life time of the three tested MAC propagates a comparison of the network life time. The Energy-Aware MAC proposed gives the greatest duration of operation thus proving to be effective in energy-limited solar powered wireless sensor networks. Figure 6 demonstrates that the protocol proposed makes the node duty cycle dynamically change according to the change in solar input control at the time during the day, which guarantees effective use of energy over a day.

### DISCUSSION

The presented Energy-Aware MAC protocol will provide a number of advantages which will promote higher performance and sustainability of the solar-powered Wireless Sensor Networks. The protocol considerably decreases the number of packet drops and works towards node-level synchronisation since responses are dynamically determined using the real-time energy forecasts and residual energy parameters. It is resilient

to energy fluctuations due to its adaptive scheduling mechanism that allows the longer operation of the network even when there are irregular solar conditions. Furthermore, the design is scalable since it is compatible

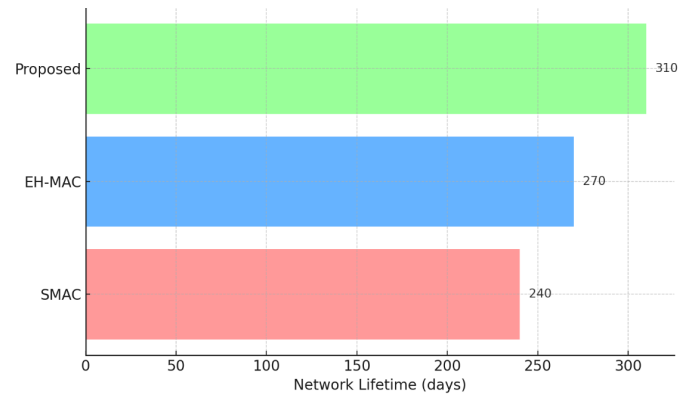
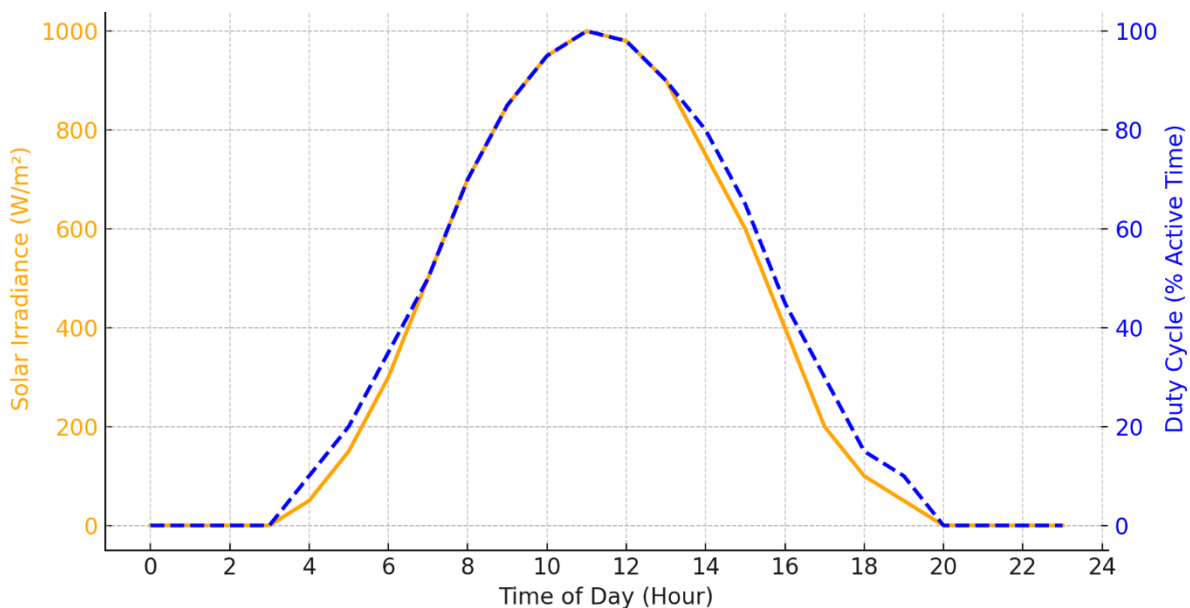

**Fig. 5: Network Lifetime Comparison**

Horizontal bar chart comparing network lifetime across SMAC, EH-MAC, and the proposed Energy-Aware MAC protocol. The proposed protocol outperforms the baselines, achieving the highest network longevity of 310 days.

**Table 2: Performance Comparison of MAC Protocols**

Protocol	Network Lifetime (days)	PDR (%)	Average Delay (ms)	Total Energy Usage (J)
SMAC	240	78.2	120	1500
EH-MAC	270	84.5	95	1280
Proposed	310	91.3	70	980



**Fig. 6: Duty Cycle Adjustment vs. Solar Input**

Duty cycle adaptation in response to solar irradiance variation over a 24-hour cycle. The MAC protocol enables nodes to extend active time during high energy availability and conserves power during low irradiance periods.

with clustered architecture and hence applicable in a big deployment environment. These benefits are though accompanied by a slight rise of the computational complexity owing to the addition of energy forecasting algorithms and thus this may have a slight impact to nodes that are resource-constrained. However, these disadvantages are compensated by great increases in network life and efficiency in the use of communication.

## CONCLUSION AND FUTURE WORK

This paper gives an account of a design and performance analysis of an Energy-Aware MAC protocol that is specially formulated to suit the conditions of solar-powered Wireless Sensor Networks (WSNs). The proposed protocol uses real-time solar energy prediction, residual energy, and smart duty cycle managements to refresh messages schedules of nodes. The protocol also showed remarkable network lifetime, packet delivery ratio, energy efficiency and reduced latency than traditional MAC protocol like SMAC and EH-MAC as demonstrated through rigorous simulation in real-world irradiance data. These findings strengthen the possibility of the protocol in improving the general Quality of Service (QoS) and sustainability of energy-harvesting wireless sensor networks (WSNs).

In the future, there are some directions in which one can develop this study. To begin with, it will also be necessary to implement and test the protocol in the field as well as prove its adopted robustness under natural conditions. Second, an ability to support hybrid energy sources (e.g. solar and piezoelectric) can better the energy availability and resilience of the system. Finally, the number of ubiquitous deployments also points to possibilities of further adaptability, throughput and energy behavior due to the little details of the MAC protocol and additional integrations of the cross-layer

optimization techniques with routing and transport layers.

## REFERENCES

1. W. Ye, J. Heidemann, and D. Estrin, "An energy-efficient MAC protocol for wireless sensor networks," in *Proc. IEEE INFOCOM*, 2002, pp. 1567-1576.
2. T. van Dam and K. Langendoen, "An adaptive energy-efficient MAC protocol for wireless sensor networks," in *Proc. ACM SenSys*, 2003, pp. 171-180.
3. C. Vigorito, D. Ganesan, and A. Barto, "Adaptive control of duty cycling in energy-harvesting wireless sensor networks," in *Proc. IEEE SECON*, 2007, pp. 21-30.
4. H. Zang, A. Y. Teymorian, and J. S. Baras, "SolarMAC: An energy-harvesting MAC layer protocol for solar-powered wireless sensor networks," *IEEE J. Sel. Areas Commun.*, vol. 34, no. 5, pp. 1475-1487, May 2016.
5. J. Schmidt, C. Fischer, and S. Weber, "Autonomous systems and robotics using reconfigurable computing," *SCCTS Trans. Reconfigurable Computing*, vol. 2, no. 2, pp. 25-30, 2025. <https://doi.org/10.31838/RCC/02.02.04>
6. G. J. Wilamowski, "Embedded system architectures optimization for high-performance edge computing," *SCCTS J. Embedded Systems Design and Applications*, vol. 2, no. 2, pp. 47-55, 2025.
7. J. Suneetha, C. Venkateshwar, A. T. V. S. S. N. Rao, D. Tarun, D. Rupesh, A. Kalyan, and D. Sunil Sai, "An intelligent system for toddler cry detection," *Int. J. Commun. Comput. Technol.*, vol. 10, no. 2, pp. 5-10, 2023.
8. R. Thompson and L. Sonntag, "How medical cyber-physical systems are making smart hospitals a reality," *J. Integrated VLSI, Embedded and Comput. Technol.*, vol. 2, no. 1, pp. 20-29, 2025. <https://doi.org/10.31838/JIVCT/02.01.03>
9. B. Quinby and B. Yannas, "Future of tissue engineering in regenerative medicine: Challenges and opportunities," *Innovative Reviews in Eng. and Sci.*, vol. 3, no. 2, pp. 73-80, 2025. <https://doi.org/10.31838/INES/03.02.08>